

STUDIO

Installation, Operation, and Maintenance Manual

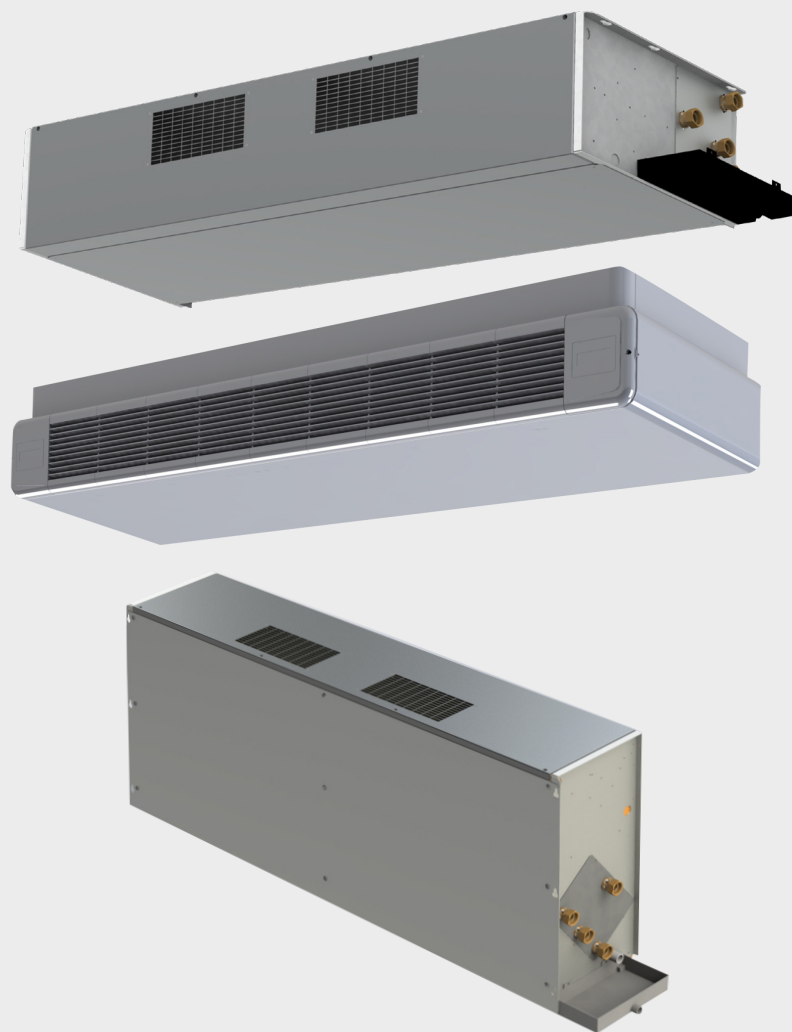

Chiller Oy will not assume responsibility for any errors or shortcomings that may appear in this document. The end user is responsible for ensuring that the unit operates appropriately and safely. Working with electric components is subject to permission. Always abide by the existing national legislation, regulations and standards.

Chiller Oy is constantly developing its products and reserves the right to change its products.

All rights reserved © Chiller Oy 2026.

Chiller Oy

Address: Louhostie 2, FI-04300 Tuusula
Finland

Telephone: +358 9 274 7670

E-mail: info@chiller.fi

Internet: www.chiller.eu

Approvals and version history

REVISION	DATE	DESCRIPTION OF CHANGE	APPROVED BY
B	11.02.2026	Updates due to the VariPro Combi control card.	TT

These are the original instructions.

Contents

- 1. General..... 4**
 - 1.1. About this manual..... 4
 - 1.2. Guarantee.....4
 - 1.3. Inspection of the unit.....4
 - 1.4. Related documentation..... 5
- 2. Safety..... 6**
 - 2.1. General safety instructions..... 6
 - 2.2. Safety-related signs..... 6
 - 2.3. Safety symbols.....6
- 3. Unit overview..... 8**
 - 3.1. Introduction of the unit..... 8
 - 3.2. Unit dimensions..... 9
 - 3.3. Type plate..... 12
 - 3.4. Automation options and control connections..... 13
- 4. Installation of the unit..... 16**
 - 4.1. General installation instructions..... 16
 - 4.2. Choosing the installation site..... 16
 - 4.3. Mounting the unit..... 18
 - 4.4. Attaching the water connections..... 20
 - 4.5. Installing sewerage for condensation water..... 22
 - 4.6. Attaching the electrical connections.....25
 - 4.7. Installing covers to the unit (option)..... 26
 - 4.8. Testing the condensation water pump..... 28
- 5. Operation of the unit..... 29**
- 6. Maintenance of the unit.....30**
 - 6.1. Maintenance schedule..... 30
 - 6.2. Cleaning and replacing the filter..... 32
 - 6.3. Cleaning the condensation water basin..... 33
 - 6.4. Cleaning the grille..... 34
 - 6.5. Opening the maintenance hatch..... 34
- 7. Technical data..... 36**

- Appendix A: Analog control connections..... 37**
- Appendix B: Register listing for Modbus control option.....39**
- Appendix C: Register listing for unit with VariPro room controller.....41**

1 General

1.1 About this manual

This Installation, Operation, and Maintenance Manual has been prepared as general instructions for appropriate installation, operation, and maintenance procedures. When operating the unit, always follow the precautionary instructions related to each component as well as the regulations and recommendations given by the local authorities.

The unit must be installed, operated, and maintained by a professional and in such a way that it does not cause danger to humans, the environment, or the unit itself. The unit must not be used for other than its intended purposes without a written consent from the manufacturer.

Caution



Read the manual

Before you start to install, operate, or maintain the system, read this manual carefully and familiarize yourself with all of the instructions. Keep the manual for later reference.

1.2 Guarantee

The guarantee for this unit is based on the general terms of guarantee of Chiller Oy.

The guarantee becomes void if:

- The product is modified or repaired without a written consent from Chiller Oy
- The unit parameters are modified without permission
- The configuration of the unit is changed
- The installation site, unit connections, installation ground, or installation procedures do not follow these instructions
- The instructions in this Installation, Operation, and Maintenance Manual are not followed

The guarantee does not cover damages if:

- The user does not follow the instructions of the manufacturer
- The unit is used in a way that it is not designed for and that causes damage to the unit
- The unit is not maintained according to the schedule and instructions in this manual



Note

Warranty claims are processed only if the complete type and serial numbers of the unit (specified in the type plate, see Section 3.3 *Type plate*) are notified to the manufacturer in written form.

1.3 Inspection of the unit

The units are shipped from the factory as assembled (apart from some accessories), wired, and tested.

When you receive the unit:

1. Inspect the delivery against the order.
2. Verify that the contents of the delivery meet the order.

3. Inspect all the delivered units carefully.
 - a) If the units have transport damages, notify the expeditor and the seller of them.
 - b) Record the transport damages on the bill of freight.
 - c) Send a complaint about the damages to the transport company within 24 hours of delivery.

1.4 Related documentation

In addition to this manual, the unit is delivered with a unit-specific wiring diagram.

If you need a new wiring diagram, you can order it. You need the serial number of the unit from the type plate for the order, see Section 3.3 *Type plate*.

2 Safety



2.1 General safety instructions

This unit is designed so that it does not expose people to hazard or risk, provided that:

- The unit is installed, operated, and maintained according to the instructions in this manual.
- No structural changes are made to the unit.

2.2 Safety-related signs

These are the safety-related signs used in this manual.

Danger	
	<p>DANGER Indicates a hazard with a high level of risk which, if not avoided, will result in death or serious injury.</p>
Warning	
	<p>WARNING Indicates a hazard with a medium level of risk which, if not avoided, could result in death or serious injury.</p>
Caution	
	<p>CAUTION Indicates a hazard with a low level of risk which, if not avoided, could result in minor or moderate injury.</p>



Note

Notes are used to indicate important information and useful tips.

2.3 Safety symbols

Hazard symbols

These symbols indicate a hazardous situation or action. Symbols are used to warn of situations, which can cause environmental damage and personal injury.



	<p>General warning sign</p>
---	-----------------------------

Table continued...

	Electrical hazard
---	-------------------

Prohibited action symbols

These symbols are used in warnings and notifications to indicate an action that should not be taken. The prohibited action symbols are shown below.

	Limited or restricted access
	Do not touch

Mandatory action symbols

These symbols are used in warnings and notifications to indicate an action that must be taken. The mandatory action symbols are shown below.

	Read the manual or instructions
---	---------------------------------

3 Unit overview

3.1 Introduction of the unit

The STUDIO cassette fan coil unit is intended for both cooling and heating indoor air. The unit is equipped with the VariPro Combi control card that offers two automation options: Analog control and Modbus control.

The unit must be installed indoors. It can be installed to a wall or ceiling.

The unit must be stored in a dry place between +5°C (minimum) and +30°C (maximum).

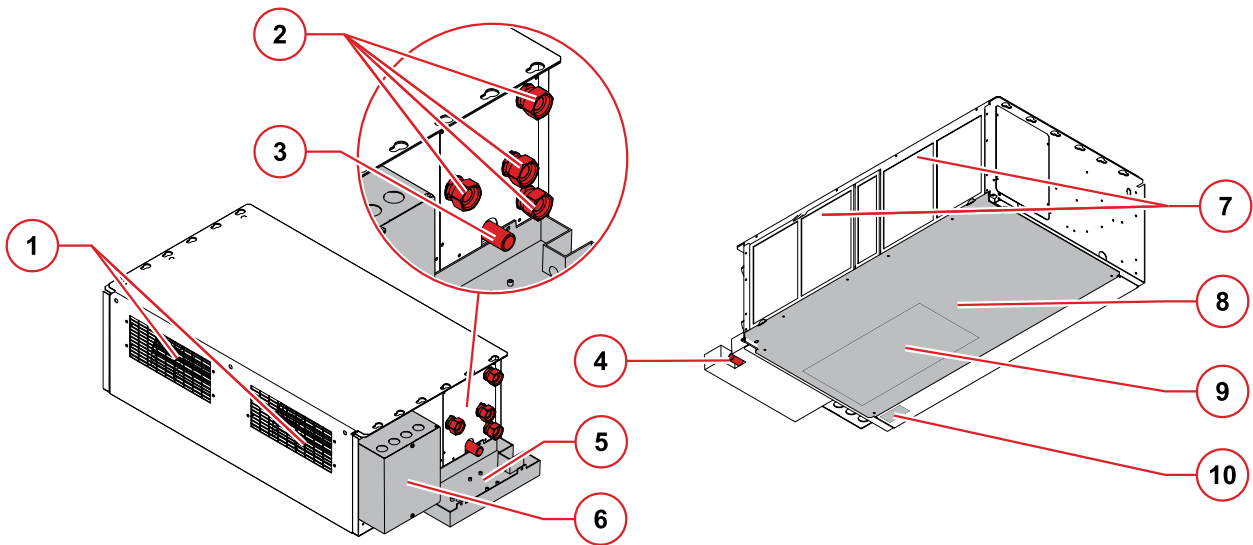

Figure 1: Overview of the unit

- | | |
|----------------------------------|---------------------------|
| 1. Air outlet | 6. Electrical connections |
| 2. Water connections | 7. Air inlet |
| 3. Condensate water outlet | 8. Maintenance hatch |
| 4. Condensate water drain outlet | 9. Wiring diagram |
| 5. External drain pan (optional) | 10. Type plate |

The unit is available as a left or right-handed version.

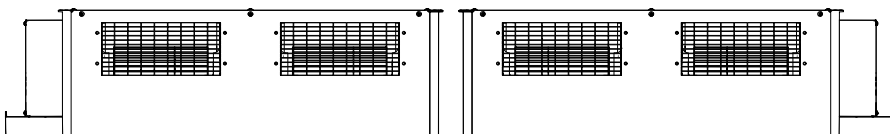

Figure 2: Left-handed unit (left) and right-handed unit (right)

The installation options for the unit are explained in Table 1 *STUDIO version explanations*.

Table 1: STUDIO version explanations

STUDIO version	Explanations
HLC	Ceiling installed model with cabinet
HLK	Ceiling installed model without cabinet
VLK	Wall installed model without cabinet (non-condensing)
VLC	Wall installed model with cabinet (non-condensing)
VC	Wall installed model with cabinet
VK	Wall installed model without cabinet

The wall-installed cabinet models can be equipped with an installation base (option JP).

3.2 Unit dimensions

The unit comes in several models and sizes, condensing/non-condensing, with or without covers. Refer to the dimensional drawings for the detailed dimensions.



Note

The unit dimensions are given as reference. Chiller Oy reserves the right to make changes to them. Check the actual dimensions from the order documentation.

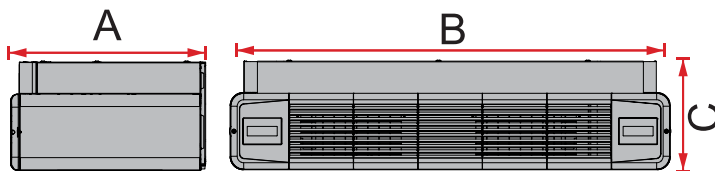

Figure 3: Studio HLC, main dimensions

Model	A (mm)	B (mm)	C (mm)
Studio HLC 9	450	1020	252
Studio HLC 10		1320	
Studio HLC 13		1620	
Studio HLC 16		1920	

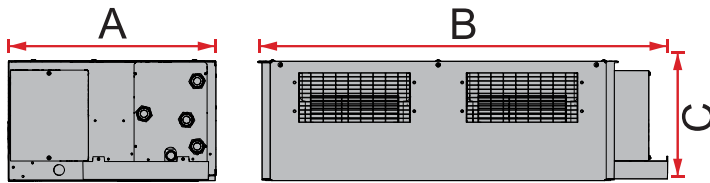

Figure 4: Studio HLK, main dimensions

Model	A (mm)	B (mm)	C (mm)
Studio HLK 9	429	752	249
Studio HLK 10		1052	
Studio HLK 13		1352	
Studio HLK 16		1652	

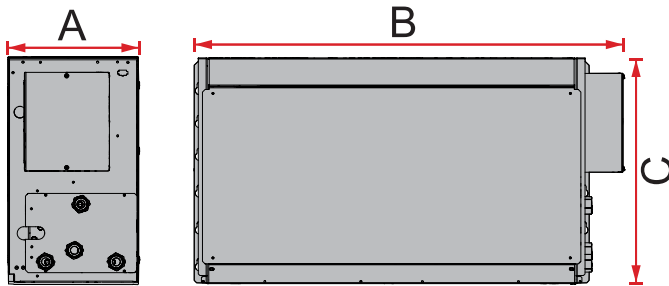

Figure 5: Studio VLK, main dimensions

Model	A (mm)	B (mm)	C (mm)
Studio VLK 9	249	752	429
Studio VLK 10		1052	
Studio VLK 13		1352	
Studio VLK 16		1652	

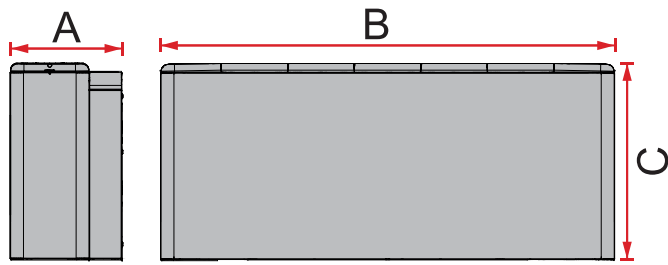

Figure 6: Studio VLC/VC without installation base, main dimensions

Model	A (mm)	B (mm)	C (mm)
Studio VLC/VC 9	252	1020	572
Studio VLC/VC 10		1320	
Studio VLC/VC 13		1620	
Studio VLC/VC 16		1920	

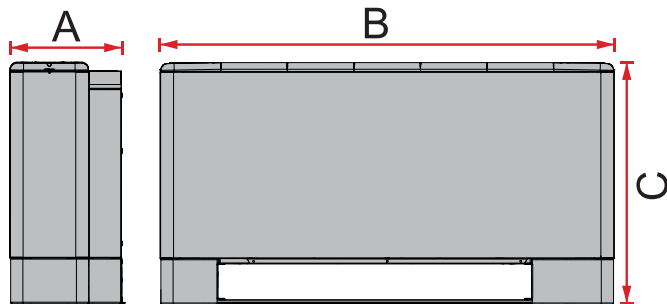

Figure 7: Studio VLC/VC with installation base (option JP), main dimensions

Model	A (mm)	B (mm)	C (mm)
Studio VLC/VC+JP 9	252	1020	662
Studio VLC/VC+JP 10		1320	
Studio VLC/VC+JP 13		1620	
Studio VLC/VC+JP 16		1920	

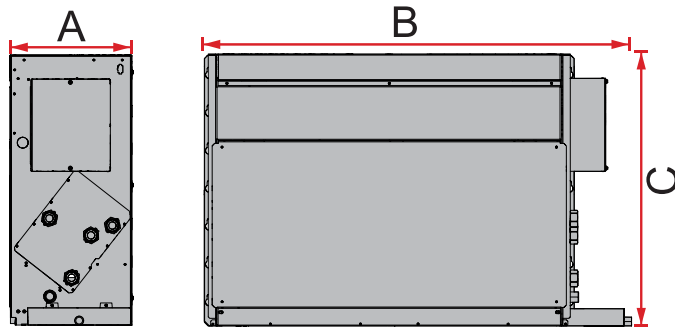

Figure 8: Studio VK, main dimensions

Model	A (mm)	B (mm)	C (mm)
Studio VK 9	249	860	550
Studio VK 10		1160	
Studio VK 13		1460	
Studio VK 16		1760	

3.3 Type plate



Note

Record the type plate information on the unit card and file it carefully. The type and serial numbers of the unit are required for identifying the unit when, for instance, purchasing spare parts.

When you order maintenance or order spare parts, you always need the serial number. You cannot make an order without the serial number.

The type plate specifies the following information about the unit:

Field	Description	Value
Type	Unit type	Including accessories. 18 characters consisting of letters and numbers.
Ser.Nr.	Unit serial number	Seven (7) number combination
Power	Power type	VAC and Hz
Input	Electrical information	Input power W and current A, max values The actual input power of the unit is usually below the max. value. For specific information, contact your nearest reseller.
Manuf.date	Date of manufacture	<DD/MM/YYYY>

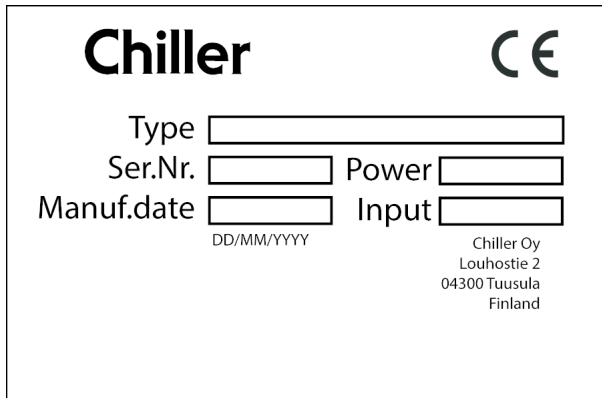

Figure 9: Example of the type plate

3.4 Automation options and control connections

The unit is equipped with a VariPro Combi control card that offers two automation options: Analog control and Modbus control. The choice of automation is made at the time of ordering the unit.

The selected automation option influences how the fan coil unit is controlled and determines the compatibility with external equipment.



Note

Always follow the wiring diagrams supplied with the unit for electrical connections.



Note

Add a 30-second filter time to alarm management when connecting the alarm signal to the BMS.

Analog automation option properties:

- Analog control (0-10 V and 24 V AC/DC for on/off on all inputs)
- Suitable for analog control from building automation or traditional room controller
- Potential free alarm contact, open in alarm or when unit not powered

See Appendix A. *Analog control connections* for further details.

Modbus automation option properties:

- Control with the VariPro wall controller or directly by Modbus RTU from the building management system
- One (1) analog sensor input which is defined during the unit ordering process
- One (1) digital control output which is defined during the unit ordering process
- No analog control options



Note

Modbus RTU control includes advanced timed functions, such as exercising the valve every 24 hours. The unit will return to normal operation upon completion of the timed function.

See Appendix B. *Register listing for Modbus control option* for further details.

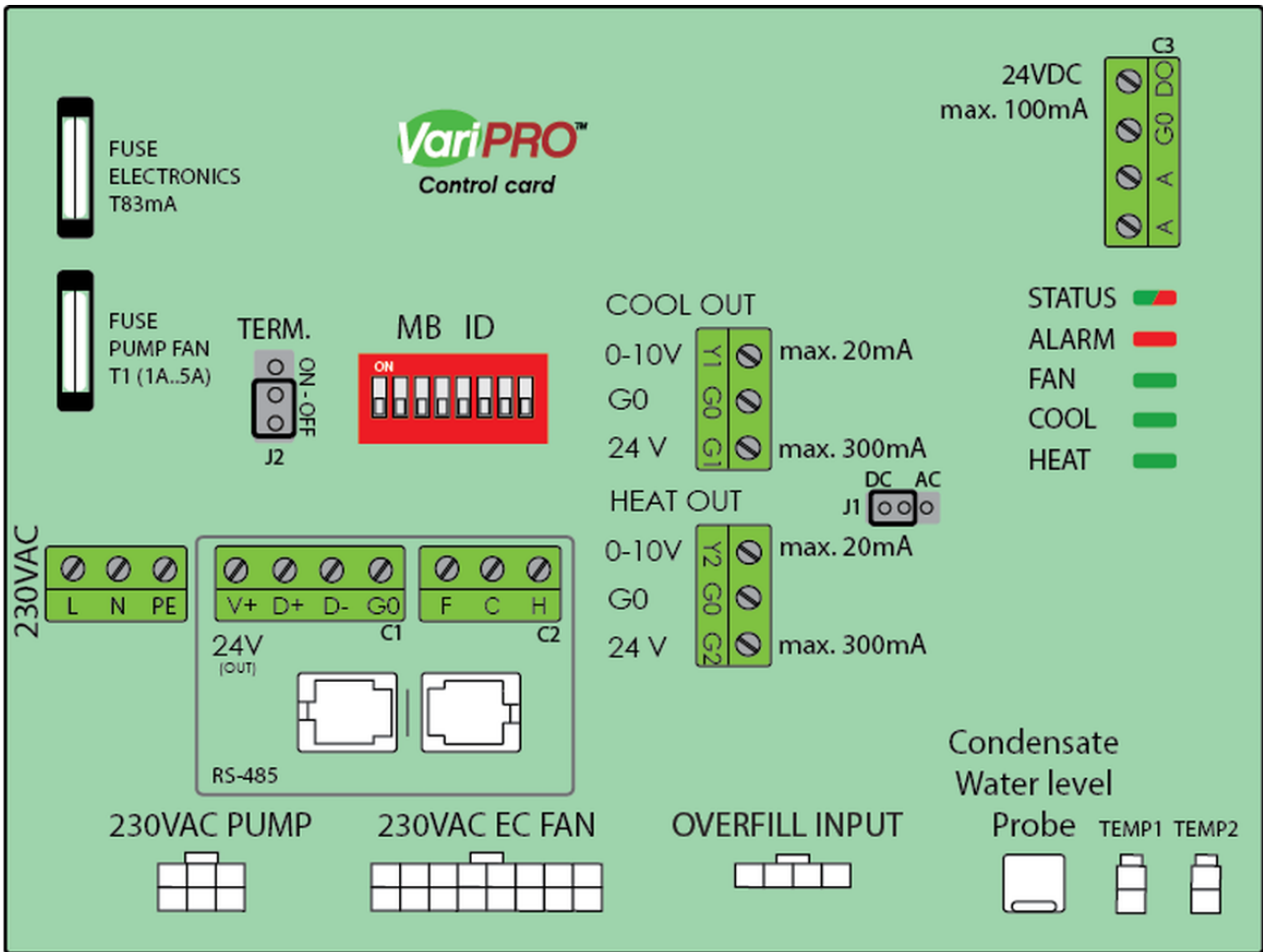

Figure 10: VariPro Combi control card layout

Table 2: Wiring instruction on the electrical box cover

V+	OUT	UI power source (24VDC)	
D+		Modbus RTU data +	
D-		Modbus RTU data -	
G0	GND	Common signal ground	
F	IN	Fan control (0-10V) ¹	
C	IN	Cooling actuator control (0-10V/24V) ²	
H	IN	Heating actuator control (0-10V/24V) ² or AI universal input ^{3, 4}	
DO	OUT	Digital output	General output for ext. relay or radiator (24VDC) ⁴
G0	GND	Digital output ground	
A	OUT	Alarm out	Open during alarm or no power (potential free contact) ⁴
A	OUT		

Table continued...

- ¹ Factory configured fan rpm scaling.
- ² Input voltage autodetected.
- ³ Digital input max. 24VDC for control or 0-10V for measurement.
- ⁴ Factory configured.

4 Installation of the unit

4.1 General installation instructions

Caution	
	<p>Risk of injury Only professionally skilled and qualified personnel can install the unit.</p>



Note

Always follow local safety regulations when you install, operate, and maintain the unit.
Read these instructions carefully before installing the unit.

When you install the unit:

- Make sure that the unit is mounted firmly and that it does not cause danger or harm to any person, object, structure, or equipment. All instructions given by the manufacturer and seller must be followed.
- Make sure that the installation, lifting, and moving the unit is performed carefully.
- Ensure fire safety and the availability of fire equipment when performing welding or soldering operations.



Note

The manufacturer is not accountable for installations that have not been performed according to the installation instructions, or for using the unit in conditions that differ from those specified in this manual.

The installation concept "Install, Use, Maintain" is applied with this unit.

The installation order of this concept is:

- Installation on the wall or ceiling (depends on the unit)
- Pipe connections
- Electrical connections
- Testing and commissioning of the unit



Note

Do not remove any of the coverings that protect the unit openings before the installation is complete and all dust has been cleared.

4.2 Choosing the installation site

When you choose the installation site for the unit, make sure that you leave enough space around the unit for maintenance work.



Note

For the exact service area requirements for each model, refer to the dimensional drawings.

For installing the unit to a wall, see the dimensional requirements for the service area in *Figure 11 Service area requirements, wall installation*.

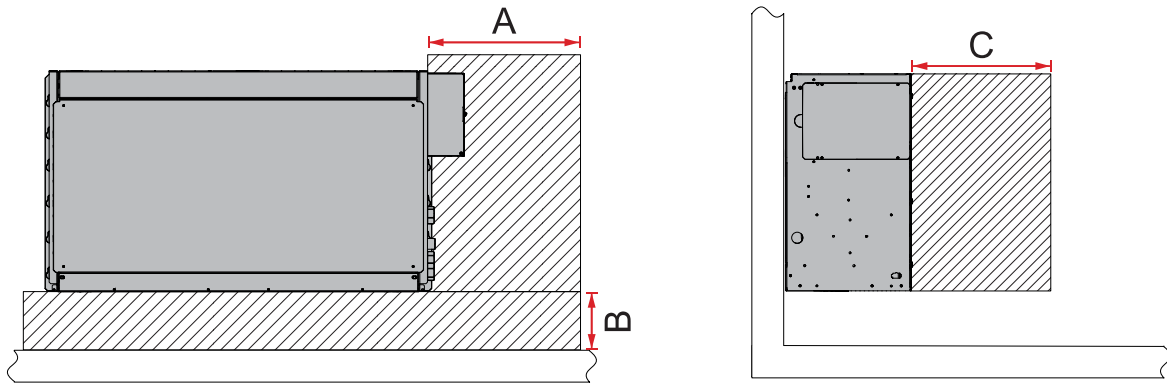

Figure 11: Service area requirements, wall installation

- A** Clear area from structures, approx. 400 mm
- B** Clear area from structures, approx. 200 mm
- C** Service area, approx. 600 mm

When installing the unit to a ceiling, make also sure that there is a maintenance hatch in the underside of the false ceiling. The recommended minimum size is 500 mm x (width of the unit + > 300 mm), see Figure 12 *Service area requirements, ceiling installation (1. Maintenance hatch)*.

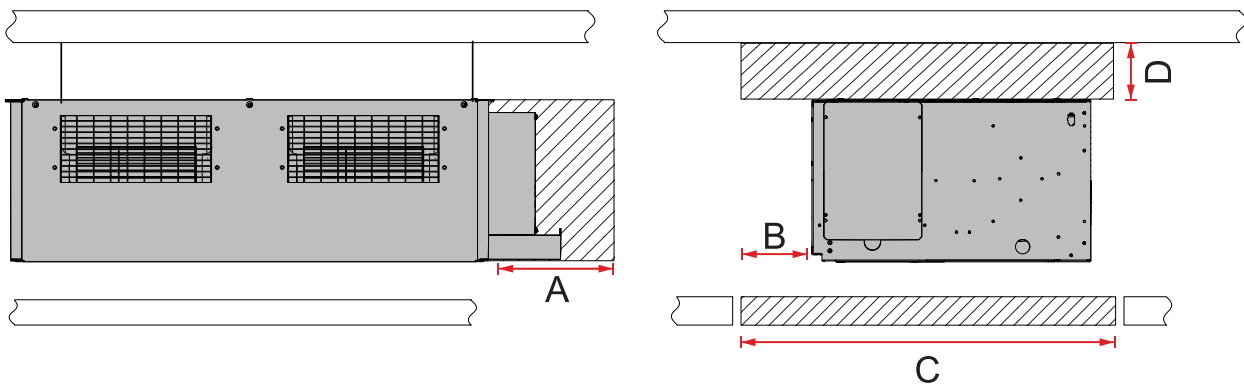

Figure 12: Service area requirements, ceiling installation (1. Maintenance hatch)

- A** Maintenance area, approx. 300 mm
- B** Clear area from structures, approx. 70 mm
- C** Maintenance hatch, approx. 500 mm
- D** Clear area from structures, approx. 30 mm



Note

Always take local safety regulations and installation requirements into account when choosing the installation site and before starting the installation.

Take also the following matters into consideration, when choosing the installation site:

- The requirements for the service room and the safety requirements for the unit and its accessories must be complied with.
- The unit must be installed in a level position.

- The unit must not be installed above any other units or equipment.
- The unit must not be installed in a room that has flammable or explosive substances or has airborne substances that corrode PVC plastics, EPS plastics, ABS plastics, copper, or aluminum.
- The unit must be installed in the room so that it allows free air circulation in the unit.
- The unit must not be installed in a room where recirculation air can bring such substances to the inlet opening of the unit that block air circulation (for instance greases from the kitchen).
- The installation and maintenance room required for electrical installations, pipe-laying, and installation of sewerage for condensation water.

Table 3: Limitations for the STUDIO installation site

Temperatures	Min.	Max.
Indoor air	5 °C ¹	26.5 °C / 50% Rh
Water	4 °C ²	80 °C ³
Ethyl alcohol (35%)	4 °C	80 °C
Ethylene glycol (35%)	4 °C	80 °C
Propylene glycol (35%)	4 °C	80 °C

¹ If the room temperature is below 0 °C, the unit must be drained of water and the condensation water must be removed.

² For lower temperatures, using anti-freeze agent is imperative.

³ The maximum water pressure is 1000 kPa/10 bar.

4.3 Mounting the unit

Install the unit to a solid structure using the attachment brackets (4 pieces). This applies also to models with housing and mounting legs. For more detailed information on weights and dimensions, refer to the dimensional drawings.



Note

Do not lift the unit from pipe joints, valves, or the condensation water basin. You can lift the unit with a drywall panel lift, or similar. Make sure that the lifting gear is rated to handle the weight of the unit. For detailed information on the weight of the unit, refer to the dimensional drawings.

Warning



Risk of severe injury

Do not stand under a suspended load.

Make sure that you attach the unit firmly to the wall or ceiling. If the unit is not properly attached, it can fall and cause severe injury.

Caution



Risk of damage to the unit

The unit must be leveled after installation. If the unit is not leveled properly, the condensation water will run in a wrong way and this can damage the unit or surroundings.

4.3.1 Installing the unit to the ceiling

The unit is mounted on the ceiling from four (4) mounting points. The mounting points are integrated in the unit frame.

To install the unit:

1. Lift the unit to the installation location.
2. Use supports to mount the unit to the ceiling. Make sure that you use supports that are suitable for the installation site and the ceiling material.



Note

The supports must be strong enough for the max. weight of the unit. Refer to the dimensional drawing for the weight of the unit.

3. Install the unit to the ceiling from the four (4) mounting points.

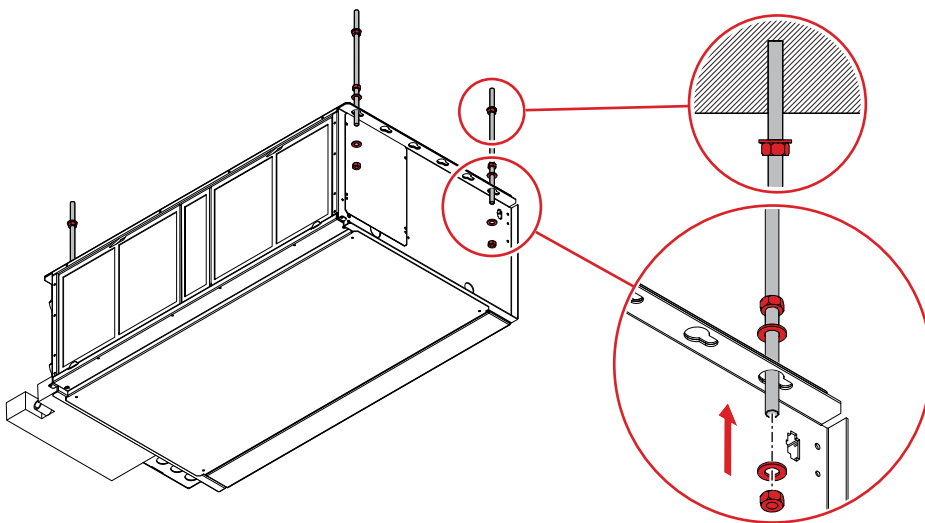

4. Make sure that the distance between the unit and the ceiling is at least 30 mm.
5. After you have mounted the unit, use a spirit level to make sure that the unit is horizontally leveled.

4.3.2 Installing the unit to the wall

The unit is mounted to the wall from four (4) mounting points. The mounting points are integrated in the unit frame.

1. Install the unit to the wall from the four (4) mounting points.
For models with housing and optional mounting legs, attach the mounting legs before the installation.

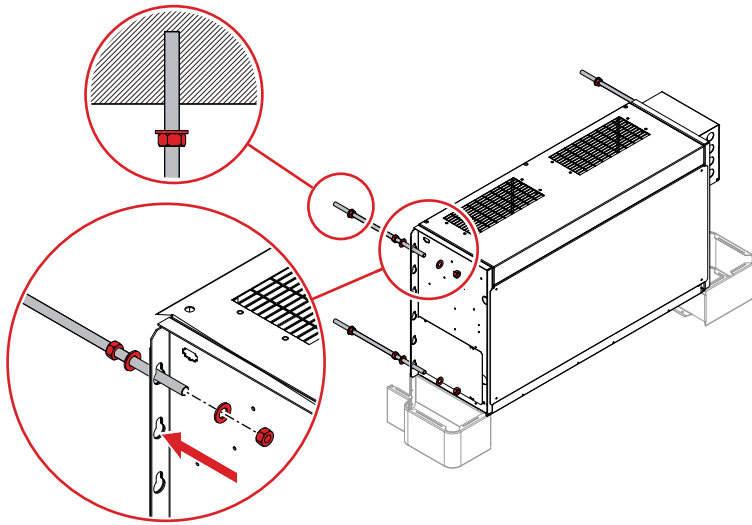

2. After you have mounted the unit, use a spirit level to make sure that the unit is horizontally leveled.

4.4 Attaching the water connections

The unit is intended to be connected to a cooling and/or heating water circulation that cannot damage the heat exchanger. More detailed information on water connections are specified separately for each order, depending on the accessories selected.



Note

Connecting the unit to the water circuit causes pressure losses. For information on unit-type specific pressure losses in the water circuit, contact the manufacturer.

1. Before you connect the unit to a cooling and/or heating water circulation, make sure that:
 - a) The maximum operation pressure of the water in the water circuit is 10 bar.
 - b) The minimum temperature of the inlet water is +4 °C.



Note

Water must never be allowed to freeze inside the coil, condensate basin, or piping of the unit.

- c) The maximum temperature of the inlet water is +80 °C.

2. Attach the water connections as shown below.



Note

The figures are illustrative. Refer to the dimensional drawings for detailed information on the connections.

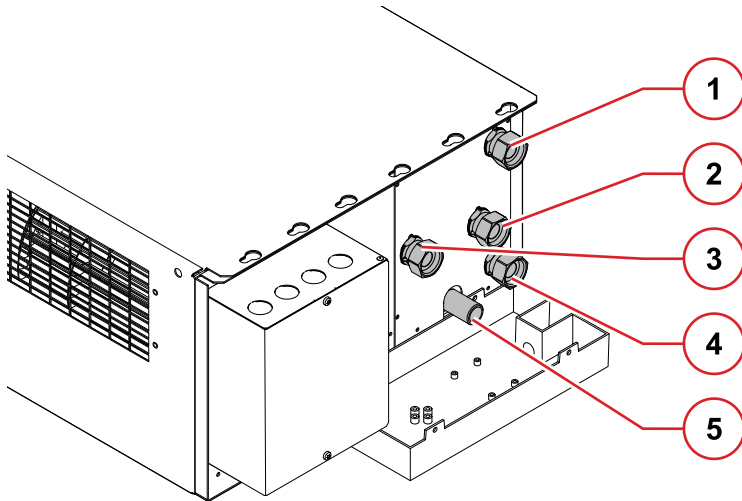

- 1. Heating water inlet
- 2. Cooling water inlet
- 3. Cooling water outlet
- 4. Heating water outlet
- 5. Condensate water outlet

Figure 13: Water connections in a unit with both cooling and heating

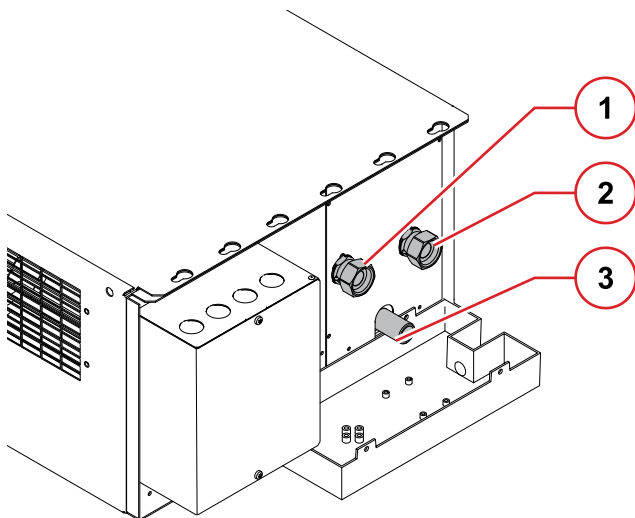

- 1. Cooling water outlet
- 2. Cooling water inlet
- 3. Condensate water outlet

Figure 14: Water connections in a unit with only cooling

- Use flat seal connectors when you attach the water connections. Make sure that the connector material is suitable for the connector type. Incorrect connector materials can damage the connection sets in the unit.

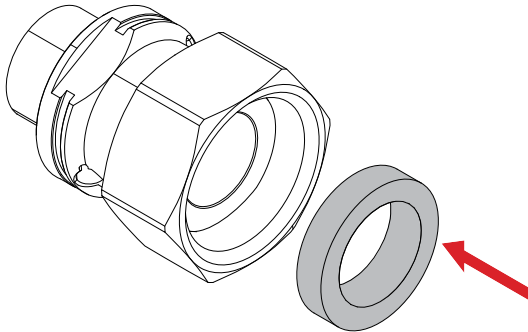

Note

Water pipes must not bend or pull the connections of the unit.



Note

The maximum tightening torques are 11 Nm (1/2") and 15 Nm (3/4"). Overtightening can break the connection joint.

4.5 Installing sewerage for condensation water

The factory-made Studio unit is available without or with (optional) a condensation water pump.



Note

Always follow the national construction regulations when you install the sewerage.

4.5.1 Sewerage without condensation water pump

When you install the sewerage:

- Make sure that the sewerage has sufficient inclination of at least 2 %.

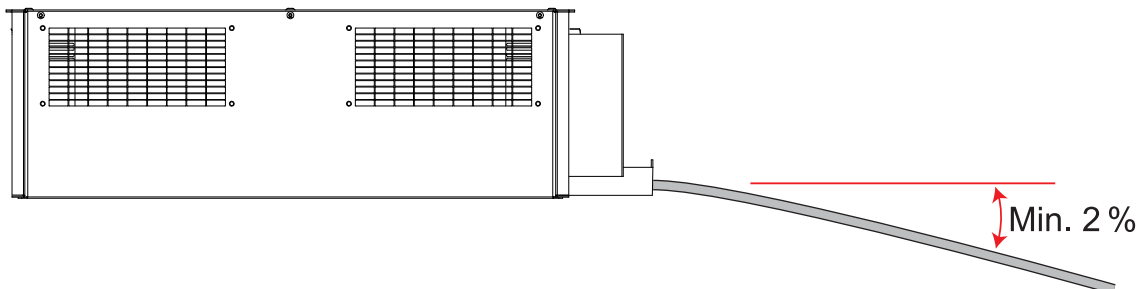

2. Make sure that you attach the pipe for the condensation water properly and the pipe is the correct size.

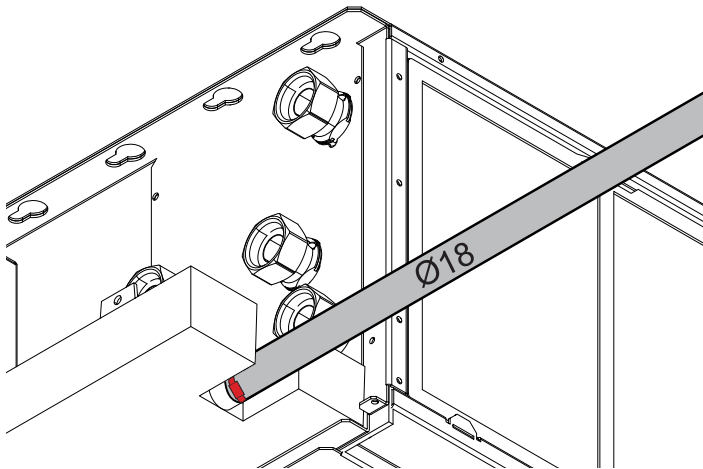

Caution	
	<p>Risk of damage to the unit Do not use excessive force when connecting the free drainage outlet as this can damage the unit and cause leakage.</p>

3. Make sure that the pipe is not bent or dented. If it is, this can decrease the flow rate or stop the flow.

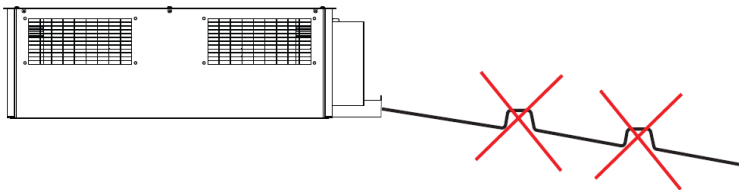

4.5.2 Sewerage with condensation water pump (option)

The unit is available with a condensation water pump for a rise of max. 1000 mm (the lifting height is stated in the type plate).

When installing the sewerage:

1. Install a drain trap to the condensation water pipeline, if condensation water is directed to the sewerage system of the property.
2. Insulate the condensation water pipe, if the unit is installed in rooms where condensation can occur on the pipe surface.
3. Support the condensation water pipe so that it does not bend at any place.
4. Make sure that you take into account the availability of supplementary air when planning the sewerage (red arrow).

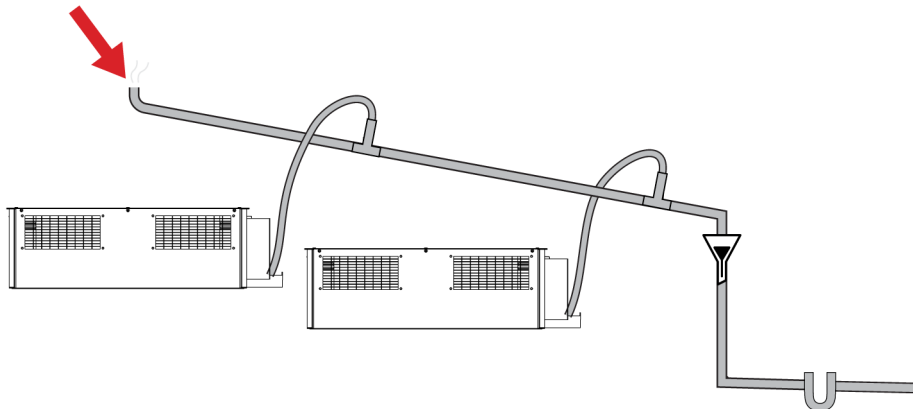

5. Connect the condensation pump hose to the sewerage from the upper side.

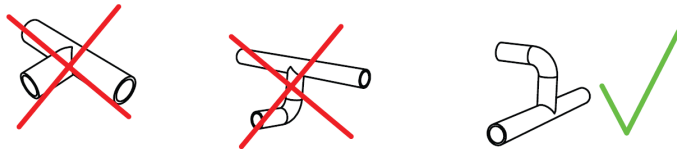

6. Make sure that the minimum radius of the hose is sufficient.
The minimum radius of the bend in the pipe: $r = 2 \times \text{pipe diameter}$.

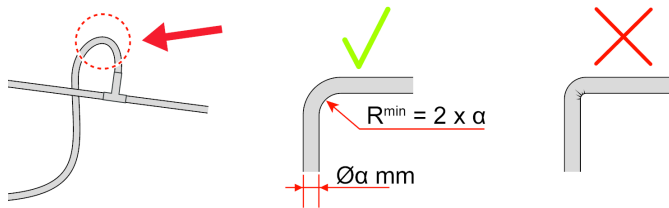

7. Make sure that the rise for the condensation water pump is max. 1000 mm.

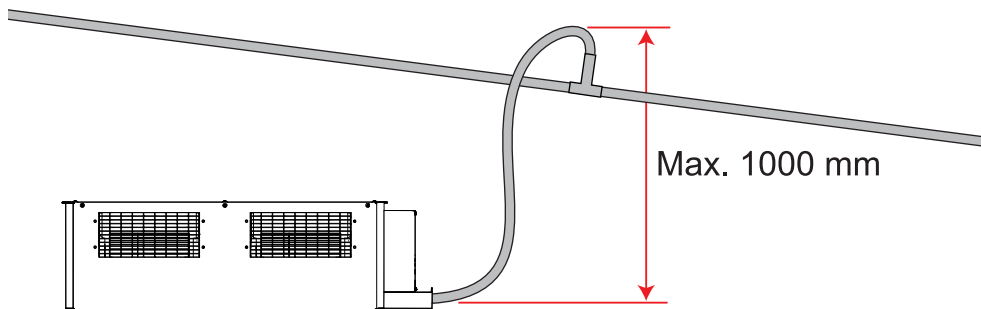

8. Connect the condensation pump hose to the sewerage through a drainage adapter.
 - a) Pull the hose through the drainage adapter to the desired length.
 - b) Cut off any excess hose, leaving 30 to 50 mm inside the adapter.
 - c) Connect the adapter to the fixed condensation pipe.



Note

You can connect the drainage adapter to a \varnothing 22 mm (outer diameter) copper pipe or to a \varnothing 32 mm (inner diameter) sewer socket.



Note

Make sure that the air venting of the drainage adaptor is facing upwards and at an inclination of max. 45°.



Note

Make sure that the condensation pump hose does not block the sewerage.

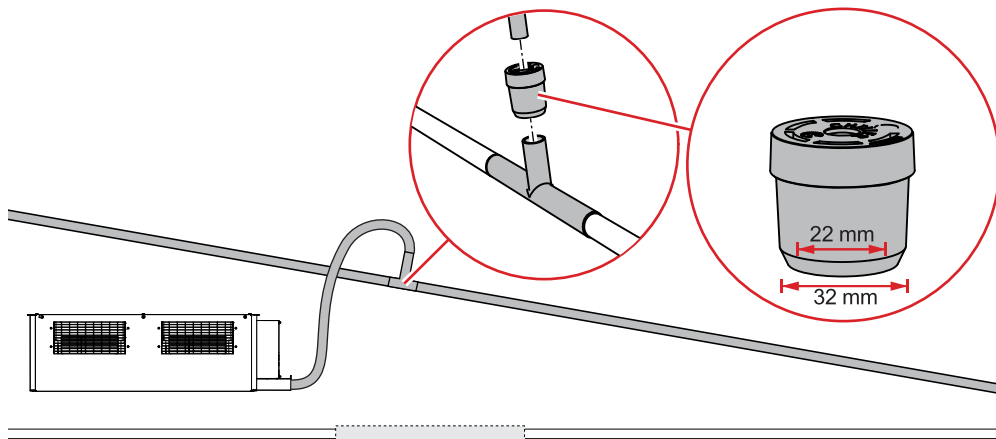

9. After installation, make sure that the horizontal inclination of the fall for the condensation sewerage is at least 2%.

4.6 Attaching the electrical connections

Danger	
	<p>Electrocution hazard Touching live parts or components of the unit can cause severe injury or death. Only qualified persons are allowed to perform electrical work on the unit.</p>
Danger	
	<p>Risk of unit malfunction, severe injury, or death The mains wiring and low-voltage control wiring must be installed separately. Never run the mains and control wiring in the same cable.</p>

Caution



Obey local laws and regulations

When connecting the unit to the circuit, make sure that the connection is done in accordance with local laws and decrees.



Note

The unit is available with VariPro equipment. The unit is delivered with model-specific electric diagrams that must be used when doing the electrical connections.

The unit is delivered as wired (including internal wirings) and connected so that the unit only needs to be connected to the supply and to possible control wirings at the installation site. Contact the seller of the unit for further information on the specific electrical and control connections of the unit and the wirings required for them.

1. When connecting the unit, make sure that the supply of the unit is protected by means of a front fuse.
2. If several units are connected in parallel behind the same supply, make sure that the size and sufficiency of the fuse is sufficient for unit-specific protection.
3. Make sure that the cable is dimensioned in accordance with the maximum values that are specified in the type plate of the unit.



Note

The power supply to the unit must always be continuous. If the power supply is off, the water condensation pump and the automation of the unit do not work.

4. Connect the external cabling on the unit to the coupling card in the link box. The coupling card contains a terminal block.

4.7 Installing covers to the unit (option)

This procedure applies only to models with housing and mounting legs.

1. Install the covers around the unit.
 - a) Slide the cover on the unit.

If you use optional mounting legs, fasten them to the unit before installing the covers.

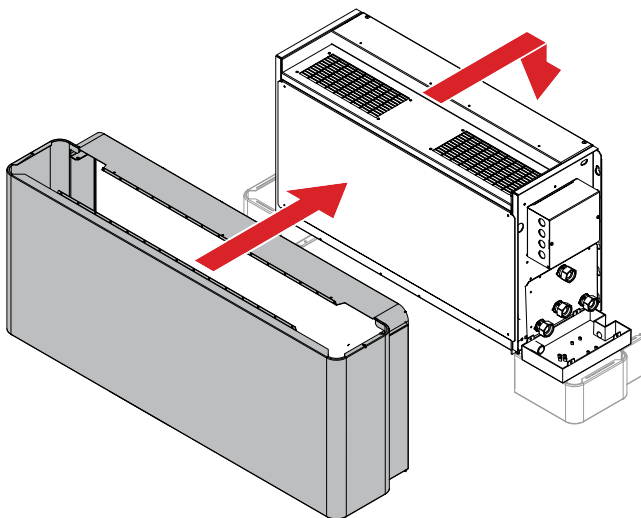

- b) Fasten the top of the cover to the unit.

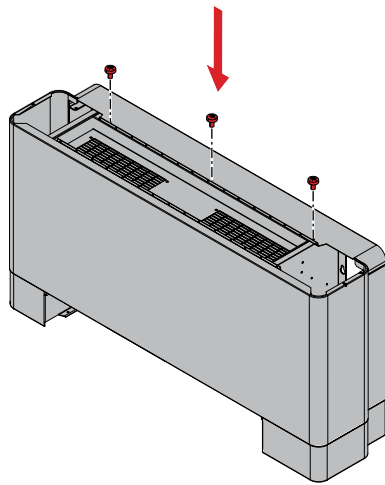

c) Fasten the bottom of the cover to the unit.

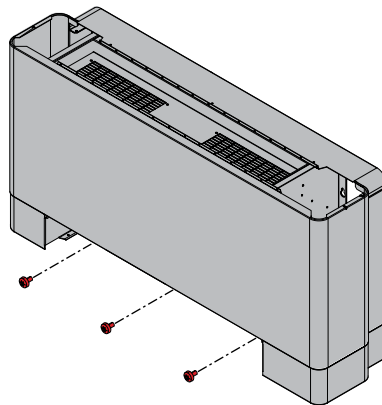

2. Install the grille to the covers.

a) Fasten the end pieces to the cover.

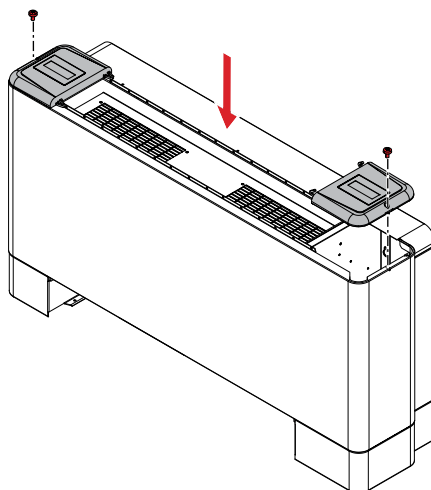

b) Install the grille.

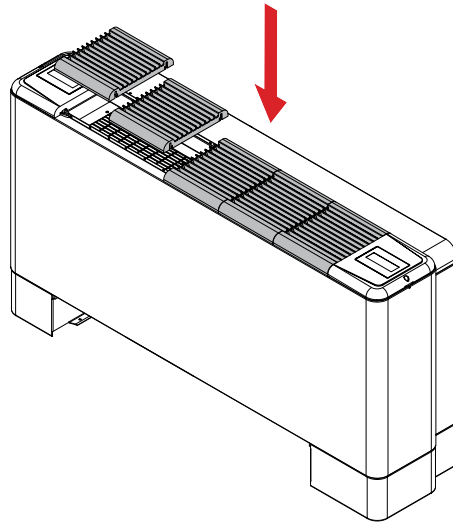

4.8 Testing the condensation water pump

Caution	
	<p>Risk of water damage You must test the condensation water pump after you have installed the unit. Do not operate the unit before you have run the test successfully.</p>

Before you can operate the unit, you must test the condensation water pump. Run a leak test after you have mounted the unit and done the necessary electrical and pipe connections.

1. To test the condensation water pump, pour approximately 2 liters of water into the external drain pan.
2. After you have poured the water into the basin, make sure that:
 - a) The condensation water pump starts.
 - b) The pump moves the water to the condensation sewerage.
 - c) The pump stops after the water has gone to the sewerage.
 - d) There are no leaks anywhere in the system.



Note

The leak test has been successful if the pump starts, moves the water, stops, and there are no leaks.

3. If the leak test was successful, you can start to use the unit.
4. If the leak test failed, do not use the unit before you have run another, successful test.

5 Operation of the unit

The fan motor of the unit is equipped with a modern EC (electronically commuted) motor. The fan motor is controlled with voltage messages of 0–10 VDC. At 0 V, the fan motor is stopped, and at 10 V, the fan motor operates at full speed.

You can adjust the room temperature by changing the speed and valve positions of the unit to achieve the set room temperature. The control valve and speed are controlled by a separate room/house automation control.

**Note**

This applies only if the unit contains two- or three-way valves.

The condensate pump is controlled internally. The condensate pump operates even if the unit is stopped with the controller or the house automation control. The unit operates independently according to the control method selected.

6 Maintenance of the unit

Danger	
	<p>Electrocution hazard Before you do any maintenance work on the unit, make sure that the unit is disconnected from the circuit and that it is de-energized.</p>

6.1 Maintenance schedule

Warning	
	<p>Risk of damage to the unit If you detect water leakage during unit operation, shut down the unit and contact maintenance.</p>

For the unit to function properly, you must do the maintenance procedures regularly. We recommend that you maintain the unit components according to the following maintenance schedule.

Table 4: Maintenance schedule

Component	Maintenance interval (years)					Action	Notes
	1/2	1	3	5	10		
Filter	X					Examine the condition of the filter.	The filter must be clean to keep the rated capacity. Cleaning with a vacuum wears out the filter over time, which is why it is necessary to replace the filter periodically. Contact Chiller for spare parts.
		X				Clean the dust from the filter with a vacuum. Rinse the filter with water.	
			X			Replace the filter.	
ViralSafe filter	X					Replace the ViralSafe filter.	The antibacterial effectiveness of the ViralSafe filter decreases over time.

Table continued...

Component	Maintenance interval (years)					Action	Notes
	1/2	1	3	5	10		
Grille	X					Examine the condition of the grille.	Clean the grille with a vacuum cleaner, then wipe with a damp cloth. Do not use any cleaning agents or solvents that can cause damage to the plastic parts.
		X				Clean the grille.	
Valve actuators *		X				Examine the operation and condition of the valve actuators.	Make sure that the actuators react to control.
Valves *		X				Examine the operation and condition of the valves.	Make sure that the valve stem moves.
Condensate water basin *		X				Examine the condensate water basin.	Make sure that there is no dust or other dirt in the condensation water basin. Clean the condensation water basin by wiping/ washing. Do not use any cleaning agents or solvents that can cause damage to the plastic parts.
			X			Clean the condensate water basin.	
Condensate water drain pump, float switch and check valve *		X				Examine the operation and condition of the drain pump, float switch and check valve.	To verify the operation of the condensate drain, fill water to the unit until the condensate drain pump starts. It is recommended to do the check in the Spring before the start of the cooling season. Contact Chiller for spare parts.
					X	Replace parts, if it is necessary.	
Condensate water drain *		X				Examine the operation and condition of the condensate water drain.	Make sure that the air vents and the drain are not blocked.

Table continued...

Component	Maintenance interval (years)					Action	Notes
	1/2	1	3	5	10		
Heat exchanger *		X				Examine the operation and condition of the heat exchanger.	When vacuuming, do not use excessive force to avoid damage to the heat exchanger. A gentle brush head is recommended. Do not use cleaning agents or solvents that can cause damage to the plastic parts or corrode copper or aluminum.
				X		Clean the heat exchanger.	
EPDM hose fittings *		X				Examine the operation and condition of the hose fittings.	Contact Chiller for spare parts.
				X		Replace parts, if it is necessary.	
Fan *		X				Examine the operation and condition of the fan.	Contact Chiller for spare parts.
					X	Replace the fan, if it is necessary.	

We recommend that the components marked with an asterisk (*) are examined and serviced by Chiller Oy, or by a service company approved by Chiller Oy.

The maintenance schedule is a recommendation only. Examine, clean and replace parts also when it is necessary.

If the unit has a VariPro room controller, reset its maintenance limit counter when servicing the unit.



Note

If there are local and/or site-specific regulations, such as hygiene regulations, that differ from the maintenance schedule above, follow the local and/or site-specific regulations.



Note

You can find more detailed instructions for maintenance in the following sections.

If other maintenance actions are needed, contact Chiller Service.

6.2 Cleaning and replacing the filter

The filter material is synthetic, and it can be cleaned with water.



Note

Replace the filter, if you cannot clean the filter as required or if the filter is damaged.

1. Clean the dust from the filter with a vacuum.

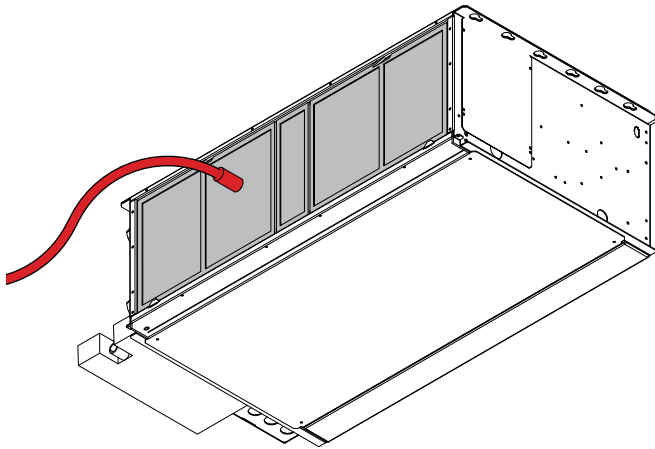

2. If the filter is still dirty after you have vacuumed it, remove the filter by lifting the hatch straight upwards and then outwards.

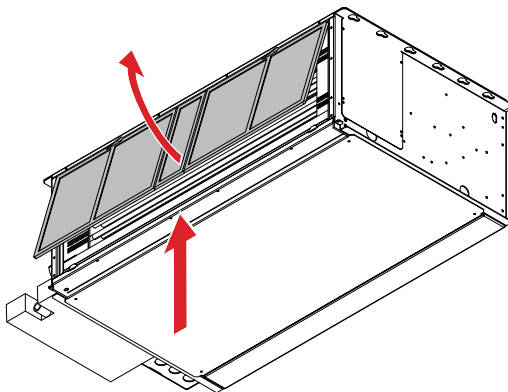

3. Clean the filter by rinsing it with lukewarm water.
4. Attach the filter to the unit.

**Note**

Before you reattach the filter to the unit, make sure that it is dry.

6.3 Cleaning the condensation water basin

1. Disconnect the pipe from the condensation water basin.
2. Remove the condensation water basin.

3. Clean the condensation water basin with a clean, damp cloth.



Note

Do not use detergents or solvents that can damage the unit.

4. Attach the condensation water basin to the unit.



Note

Before you reattach the condensation water basin to the unit, make sure that it is dry.

5. Attach the pipe.
6. Pour water to the basin. Test that the condensation water pump/sewerage works correctly.

6.4 Cleaning the grille

1. Clean the grille with a vacuum cleaner.
2. Wipe with a damp cloth.



Note

Do not use any cleaning agents or solvents that can cause damage to the plastic parts.

6.5 Opening the maintenance hatch

Warning	
	<p>Risk of injury Always support the maintenance hatch with one hand while opening. The hatch will fall off and can cause injury, if it is not supported.</p>



Note

In regular maintenance actions, it is not necessary to open the maintenance hatch.

To open the maintenance hatch:

1. Loosen the screws (2 pcs).

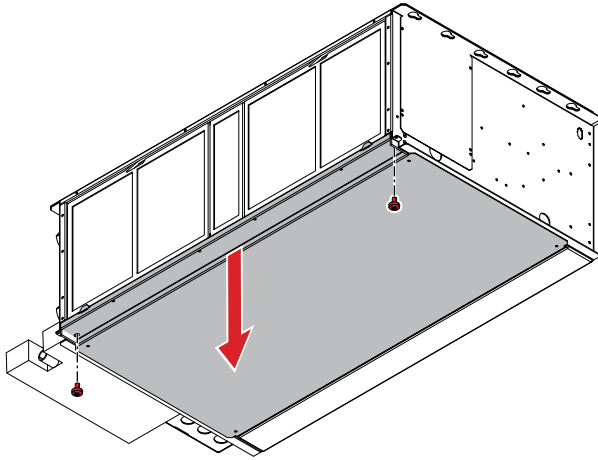

2. Open the maintenance hatch.

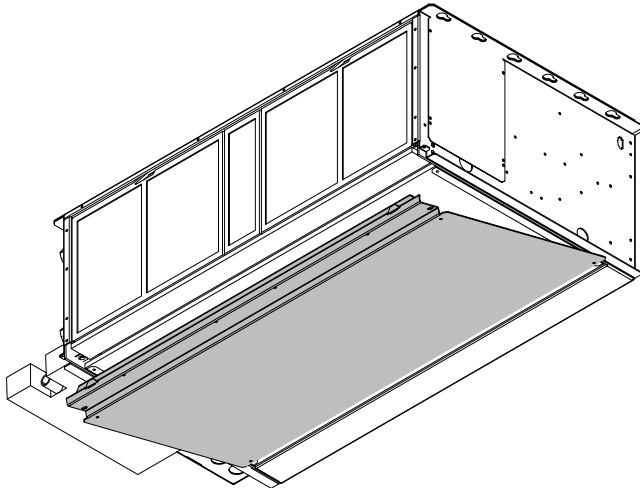

7 Technical data

Table 5: Technical data

Property	Value
Power	230 VAC, 50 Hz
Input power (W) and current (A) (max. values)	80 W, 0.8 A (Reference values)
Indoor air temperature	5 ... 32 °C
Water pressure (max.)	10 bar
Inlet water temperature	4 ... 80 °C

Information on the unit is specified in the type plate. The type plate is located in the inlet opening, behind the intake grille and the filter.

Appendix A: Analog control connections

Table 6: Analog control connections

Connector		Function	Technical description
PWR	L	230 V AC/line	Fuse on card, max. 5 A
	N	230 V AC/neutral	
	PE	Protective Earth	
C1	V+	24 V auxiliary output from the control card. Selectable between AC or DC with jumper.	Default DC. Max. output current 0.6 A (varies down depending on unit configuration).
	D+	Not in use	
	D-	Not in use	
	G0	Signal ground. All I/O signals are referenced to this connector.	Common for aux. 24 V output, 0–10 V control inputs, 0–10 V control outputs 24 V AC/DC control inputs and 24 V AC control outputs. Not connected to Protective Earth (PE).
C2	F	Fan speed input, 0–10 V (linear) or 24 V AC/DC for ON/OFF control.	Impedance 50 kΩ. Desired control mode detected automatically.
	C	Cooling valve control input, 0–10 V (linear) or 24 V AC/DC for ON/OFF control.	Impedance 50 kΩ. Desired control mode detected automatically.
	H	Heating valve control input, 0–10 V (linear) or 24 V AC/DC for ON/OFF control.	Impedance 50 kΩ. Desired control mode detected automatically.
C3	D0	Not in use	
	G0	Not in use	
	A	Alarm connection (in or out)	OPEN when alarm active or unit not powered. Potential free.
	A	Alarm connection (in or out)	OPEN when alarm active or unit not powered. Potential free.
COOL OUT	0–10 V	0–10 V valve output for cooling actuator	Follows C input
	G0	Same as in connector C1	Same as in connector C1
	24 V	24 V AC PWM output for cooling actuator / 24 V AC power output for 0–10 V actuators	Follows C-input, or continuous 24 V AC output voltage

Table continued...

Connector		Function	Technical description
HEAT OUT	0–10 V	0–10 V valve output for heating actuator	Follows H-input
	G0	Same as in connector C1	Same as in connector C1
	24 V	24 V AC PWM output for heating actuator / 24 V AC power output for 0–10 V actuators	Follows C-input, or continuous 24 V AC output voltage

Appendix B: Register listing for Modbus control option



Note

Observe proper delays when communicating over Modbus. Use at least 200 ms polling delay. If you observe bus errors, increase the delay until there are no errors. Continuously rewrite (= refresh) fan speed, cooling valve, and heating valve registers at least every 5 minutes, even when desired value is 0. Always write to all 3 registers, even if there is no heating (or cooling) option in the unit.

When controlling the fan coil directly (without the room controller), use the following register map.

Table 7: Register listing for Modbus control option

VariPro FCU Controller Card Register Map v 1.4					Modbus RTU RS485 38400, 8N1	
	Description	Read/Write	Min.	Max.	Unit	Note(s)
Write register 16 bit integer register						
4x00002	Set fan speed	W	0	100	%	0...100 = 0...10 V 0 = OFF 100 = ON 24 V
4x00003	Set cool output	W	0	100	%	0...100 = 0...10 V 0 = OFF 100 = ON 24 V
4x00004	Set heat output	W	0	100	%	0...100 = 0...10 V 0 = OFF 100 = ON 24 V
4x00101	Reset service reminder counter	W	0	1		1 = reset
4x35203	Manufacturing year	W	20xx	20xx		By reading this data, modbus register configuration and address alignment can be validated.
4x35204	Manufacturing month	W	1	12		
4x35205	Manufacturing day	W	1	31		
Read register 16 bit integer register (*)						

Table continued...

VariPro FCU Controller Card Register Map v 1.4					Modbus RTU RS485 38400, 8N1	
	Description	Read/Write	Min.	Max.	Unit	Note(s)
3x00005	Alarm register	R				Bit0: Condense sensor alarm Bit1: Missing RPM from fan1 Bit2: Missing RPM from fan2 Bit3: Sensor fault, water in Bit4: Sensor fault, water out Bit11: Parameter file Bit15: Service reminder (Filter alarm)
3x00007	Current fan speed output	R	0	100	%	Scaled to maximum speed
3x00010	Condensate tank state	R	0	3		Level 2 pump start, 3 alarm
3x00011	Condensate pump status	R	1	16		1 = OFF, 16 = ON
3x00012	Cooling output	R	0	1000	x10mV	Scaled to maximum flow
3x00013	Heating output	R	0	1000	xx10mV	Scaled to maximum flow
3x00018	Temperature water in	R			x10C	
3x00019	Temperature water out	R			x10C	
3x00025	Service reminder counter	R			h	

(*) Reading via User Interface
 Address: 3x00N (RR-2), where: N = Unit count, RR = Register address
 Example: 3x00010 (Condensate tank state) from 1st unit, user interface address 3x00108

Appendix C: Register listing for unit with VariPro room controller

When controlling the fan coil with the room controller, use the following register map.

Table 8: Register listing for a unit with a VariPro room controller

VariPro User Interface Register Map v 1.4					Modbus RTU RS485 Baudrate: 9k6, 19k2, 38k4 Parity: None, odd, even	
	Description	Read/Write	Min.	Max.	Unit	Note(s)
Write register 16 bit integer register						
4x00001	Application state	W				1 = Stand-by (OFF) 2 = Normal 3 = Away 4 = Flush (set cool & heat 100%) 5 = Stopped 10 = Test mode (allow cool/ heat without fan)
4x00003	Fan speed control	W				0 = OFF, 1–3 = Speed,4 = Auto
4x00004	Room set point, Normal	W			x10C	
4x00005	Room set point, Away	W			x10C	
Read register 16 integer register						
3x00004	Application state	R				0 = Init 1 = StandBy 2 = Normal 3 = Away 4 = Flush 10 = Test
3x00006	Current fan control	R	0	4		0 = OFF, 1–3 = Speed,4 = Auto

Table continued...

VariPro User Interface Register Map v 1.4					Modbus RTU RS485 Baudrate: 9k6, 19k2, 38k4 Parity: None, odd, even	
	Description	Read/Write	Min.	Max.	Unit	Note(s)
3x00007	Room temperature	R			°C	x10
3x00008	Current room set point	R			°C	x10
3x00009	Current fan speed	R	0	100	%	
3x00010	Cooling output	R	0	100	%	
3x00011	Heating output	R	0	100	%	
3x00103	Alarm "Unit 1"	R				Bit0: Condense sensor alarm Bit1: Missing RPM from fan1 Bit2: Missing RPM from fan2 Bit3: Sensor fault, water in Bit4: Sensor fault, water out Bit11: Parameter file Bit15: Service reminder (Filter alarm)
3x00203	Alarm "Unit 2"	R				

CHILLER

Part of Koja Group.

www.chiller.eu